

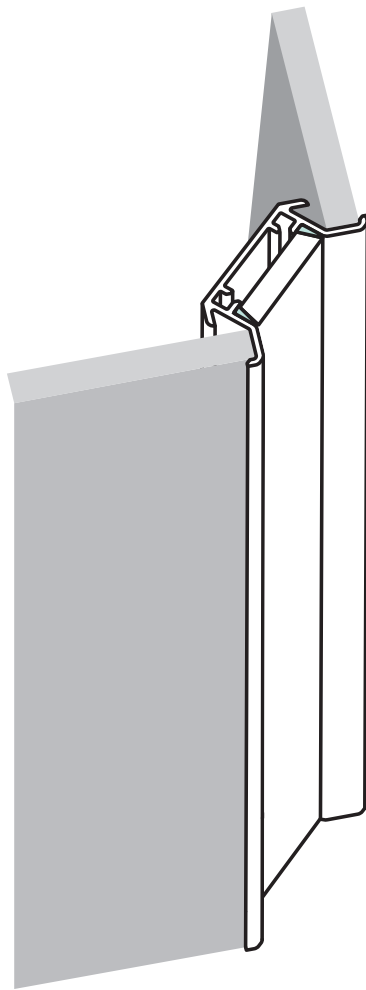

TECH[®]
LIGHT

INSTALLATION INSTRUCTIONS

waterproof profile



P11-3

CONTENTS

COMPONENTS PREPARATION.....	3
SEALING THE ENDS OF LED STRIP.....	4
END CAPS INSTALLATION.....	5
LED TAPE INSTALLATION.....	6
SEALING BEFORE COVER INSTALLATION.....	7
COVER INSTALLATION.....	8
PROFILE IN-GROUND INSTALLATION.....	9
PRECAUTION.....	10

Attention!

The profile shown in the instructions may differ in appearance from the actual product. However, the installation method remains the same.

All profiles and covers have been manufactured with a positive tolerance.
They must be cut to the required length before installation.

COMPONENTS PREPARATION

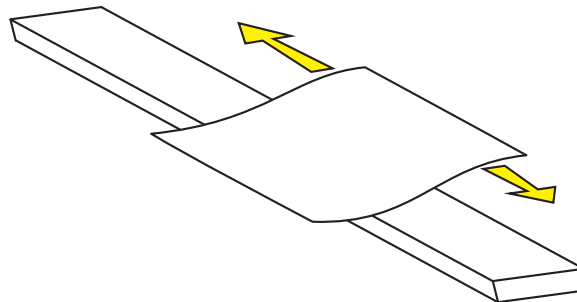
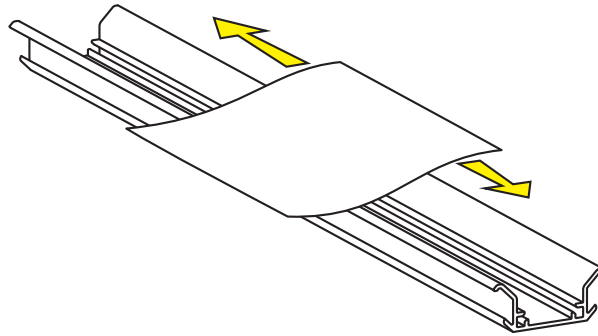
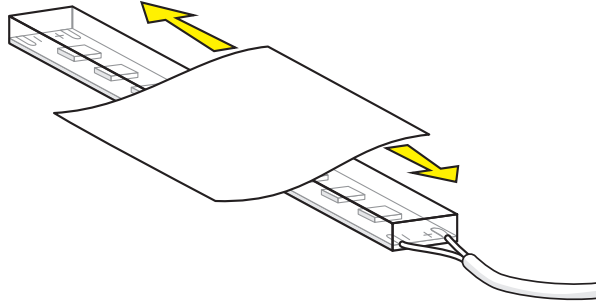

Clean all components from dust and dirt.

SEALING THE ENDS OF LED STRIP

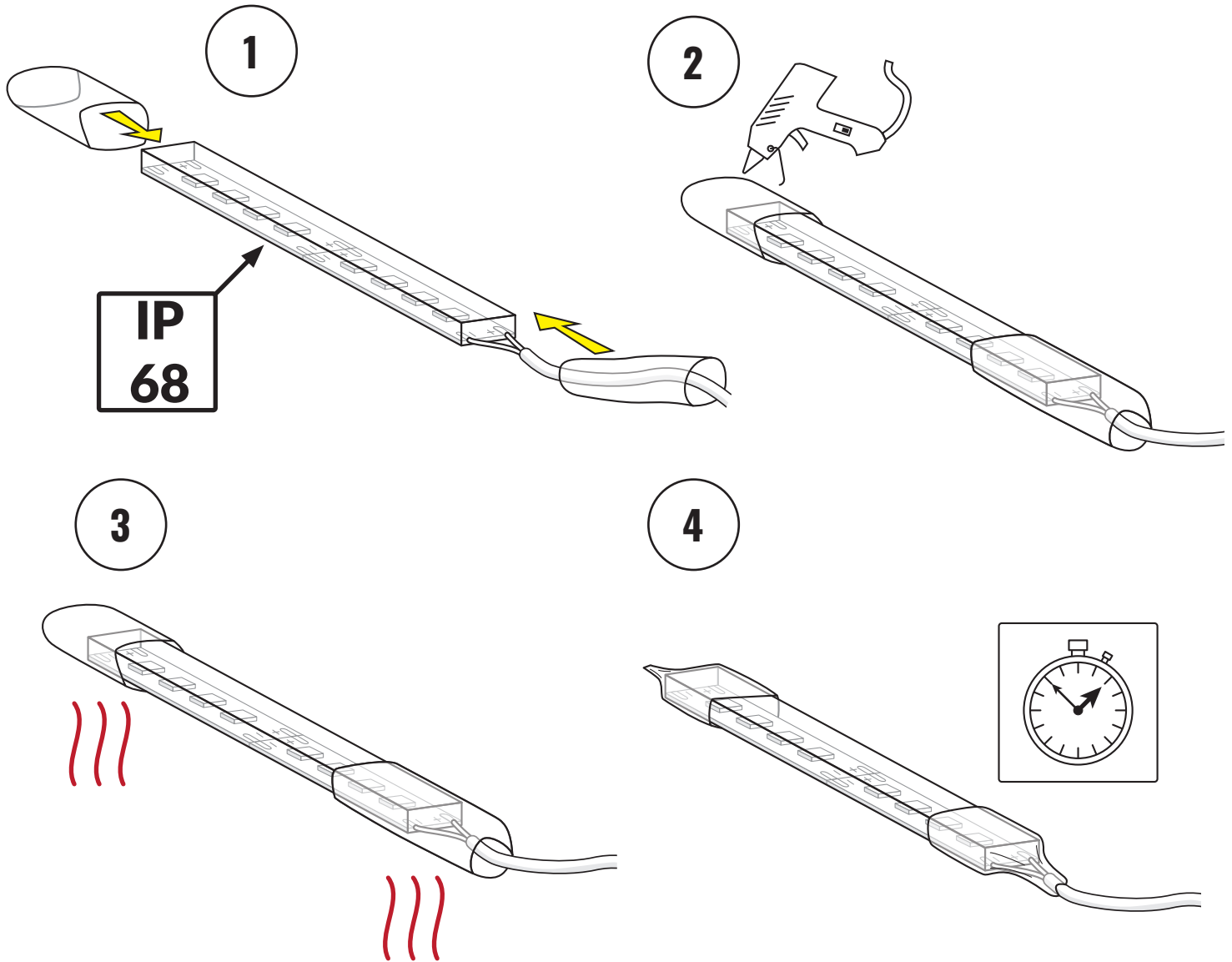

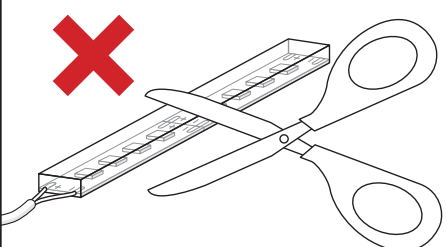

ATTENTION!
Do not cut the hermetic LED strip.
After cutting, the LED strip loses its waterproof properties.
Additionally, add protection from external factors at the ends.

1. Place heat shrink tubes on the ends of the LED strip
2. Fill the space inside heat shrink tubes with hot glue for waterproofing of the LED strip
3. Shrink tubes using heat
4. Wait until the glue congeals

END CAPS INSTALLATION

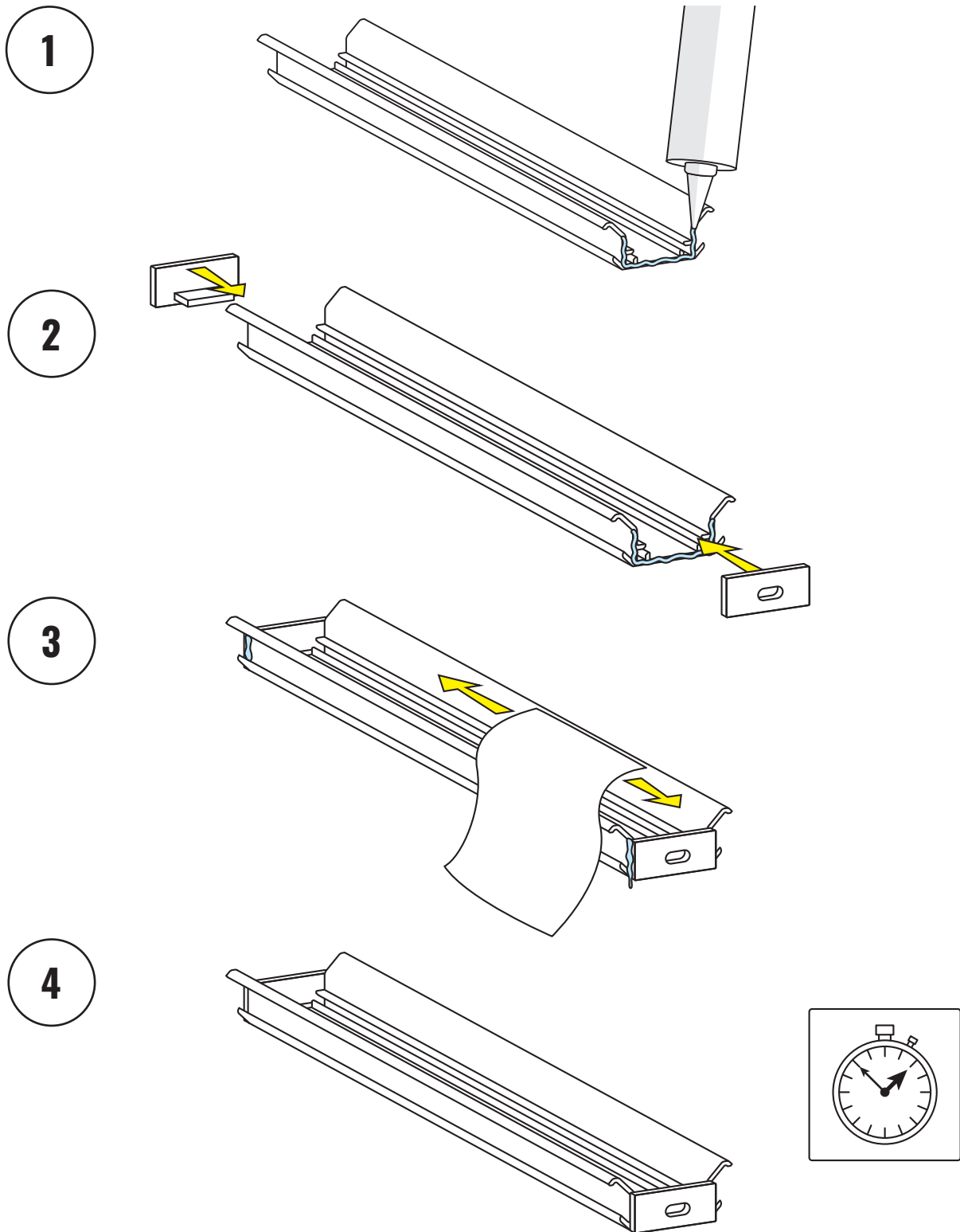

1. Prepare the profile
2. Apply silicone to both ends of the profile to create a tight seal
3. Wipe off the excess silicone from the outside
4. Wait 12 hours until silicone dries

LED TAPE INSTALLATION

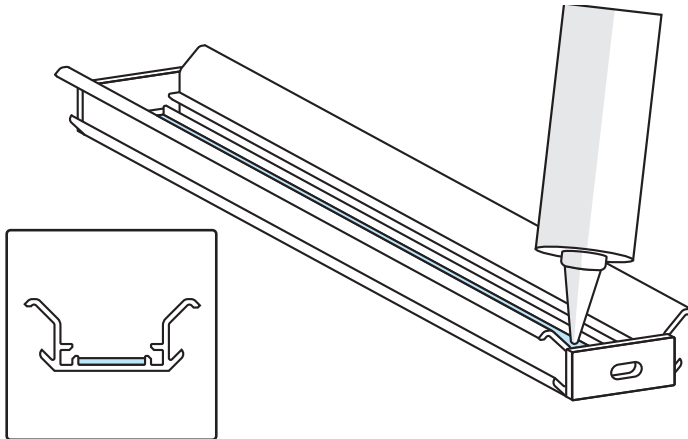
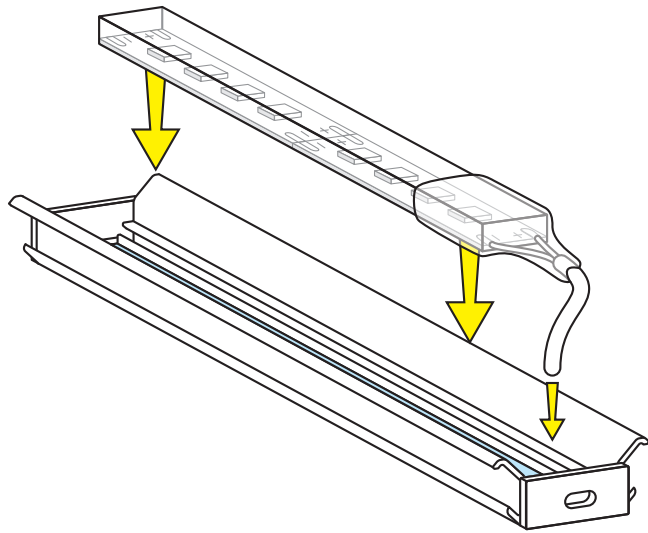
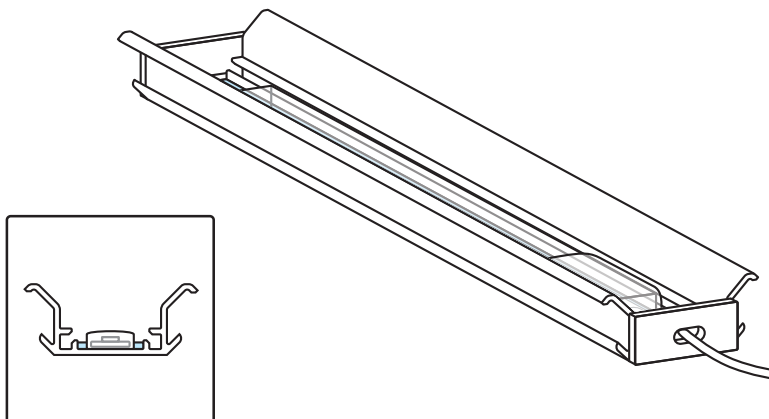
1**2****3**

1. Spread thin layer of silicone at bottom of profile
2. Thread the cable through the end cap and embed the LED strip in the silicone
3. Wait until silicone dries

SEALING BEFORE COVER INSTALLATION

Warning! The profile requires sealing if it will be used in areas with increased humidity or where there may be direct contact with liquid.

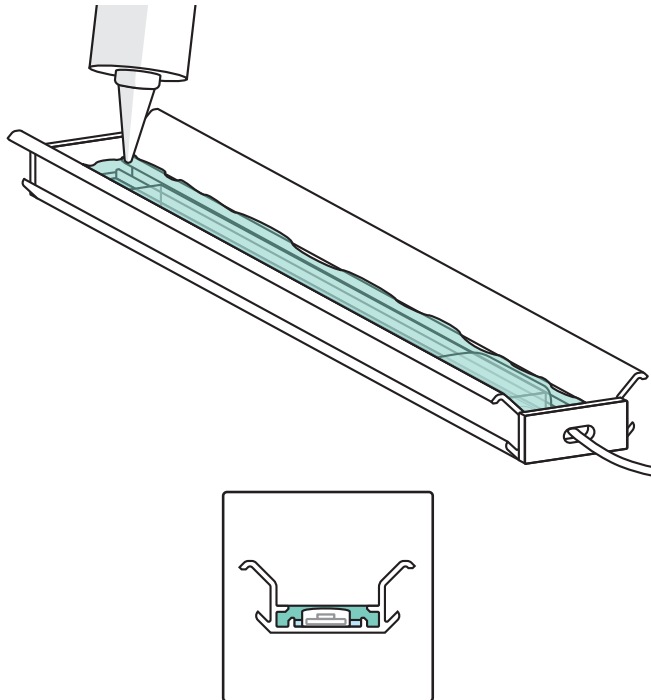
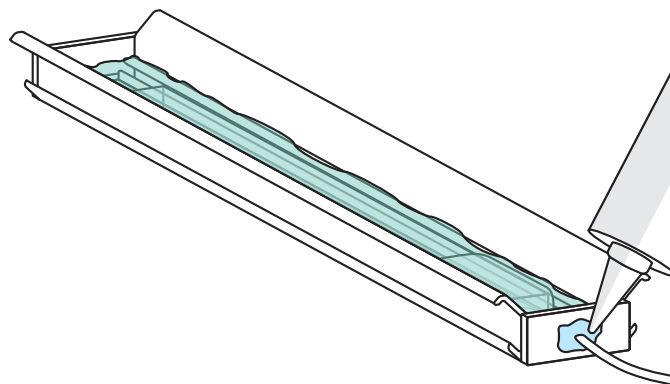
1**2**

1. Fill the interior of the profile with transparent silicone
2. Add silicone protection around the end caps hole around the cable

COVER INSTALLATION

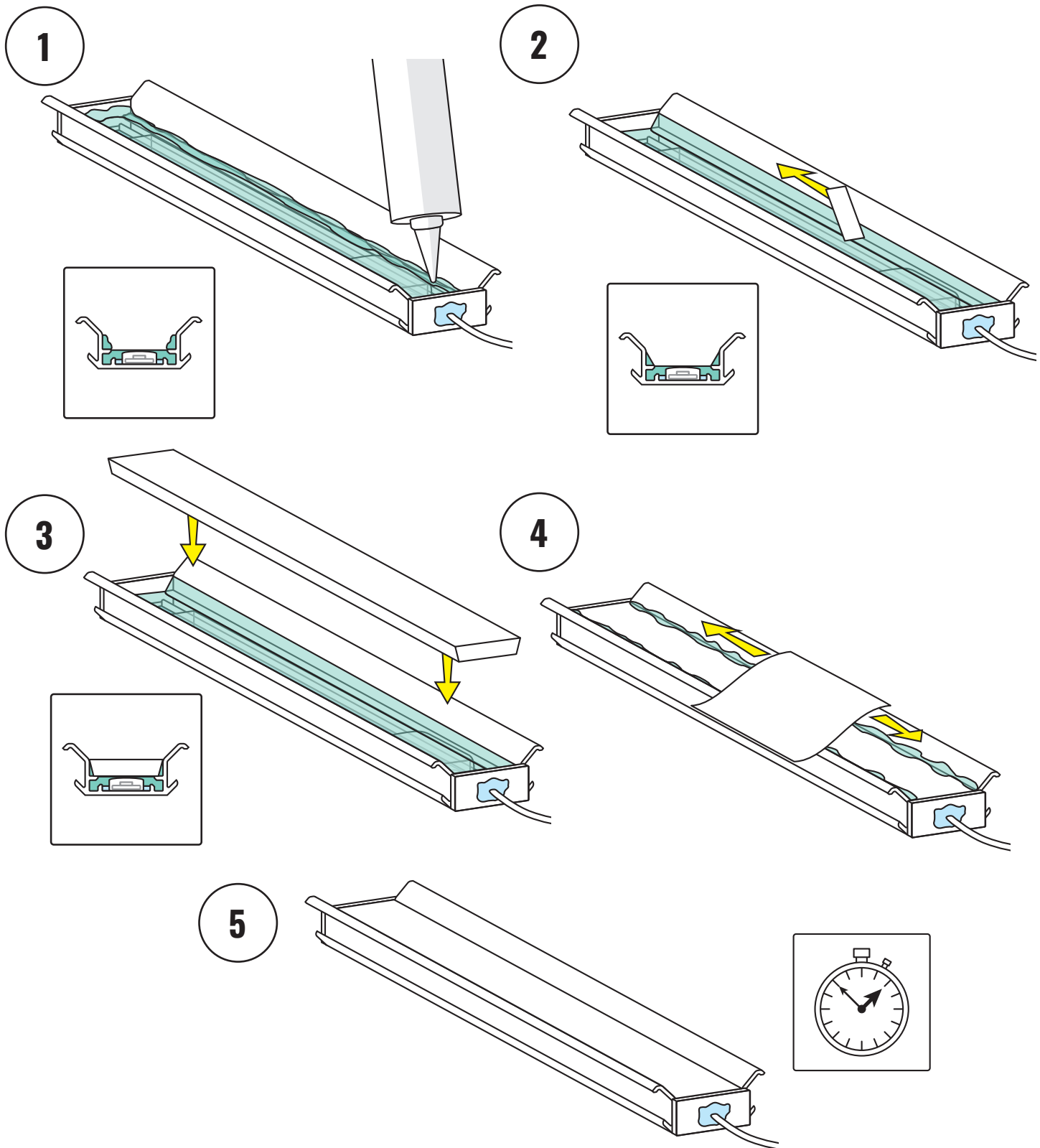

1. Spread thick layer of silicone around the edges where cover will be installed
2. Level the silicone layer so that it adheres to the wall
3. Fit the cover and press it firmly against the profile
4. Wipe off the excess silicone
5. Wait 10 days until silicone dries completely

PROFILE IN-GROUND INSTALLATION

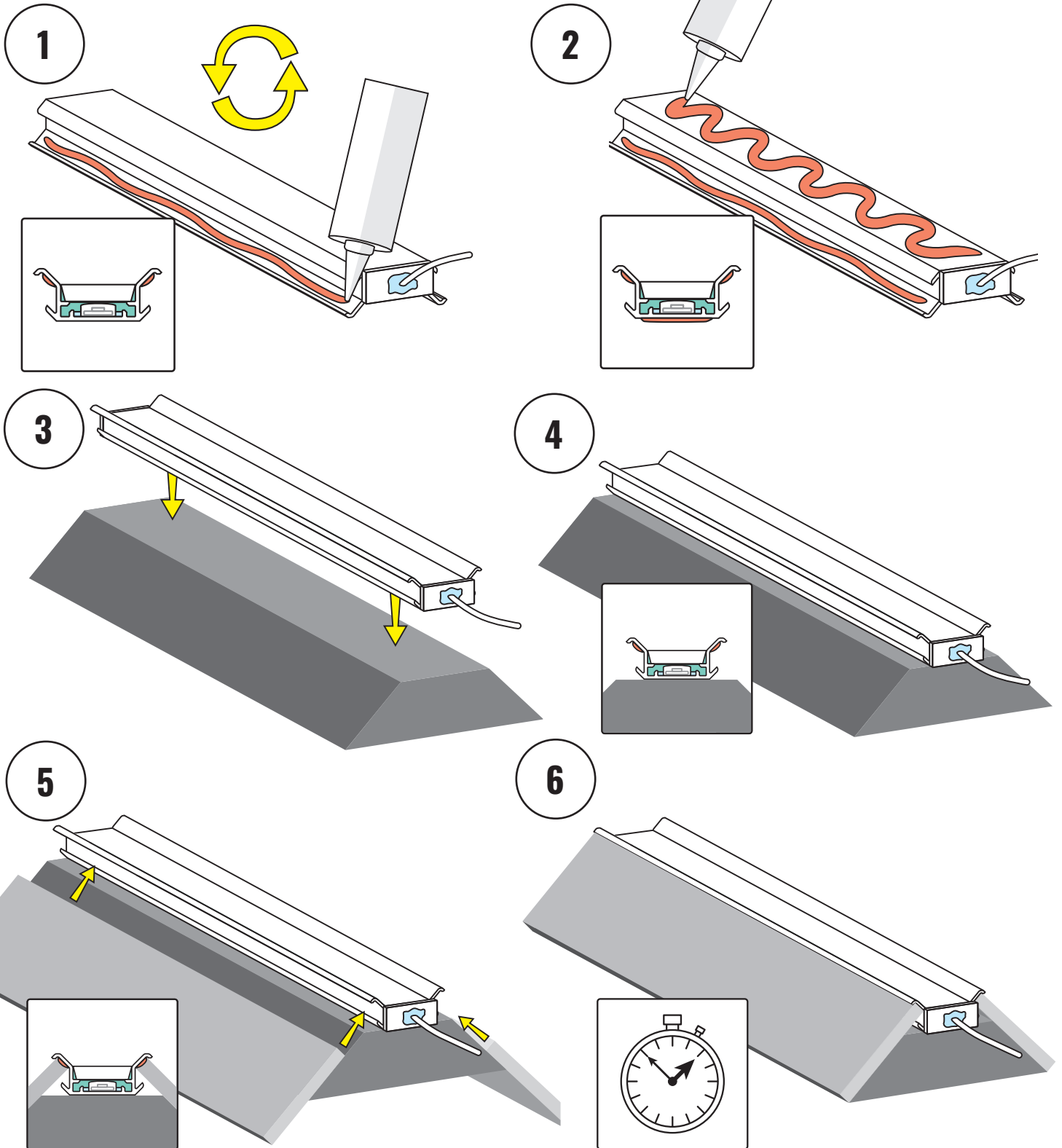

1. Spread the glue under the sides
2. (Optional) Spread the glue on the underside of the profile
3. Attach the profile to the surface
4. The profile is attached
5. Slide the tiles under the profile
6. Wait 24 hours for the glue to set

PRECAUTION

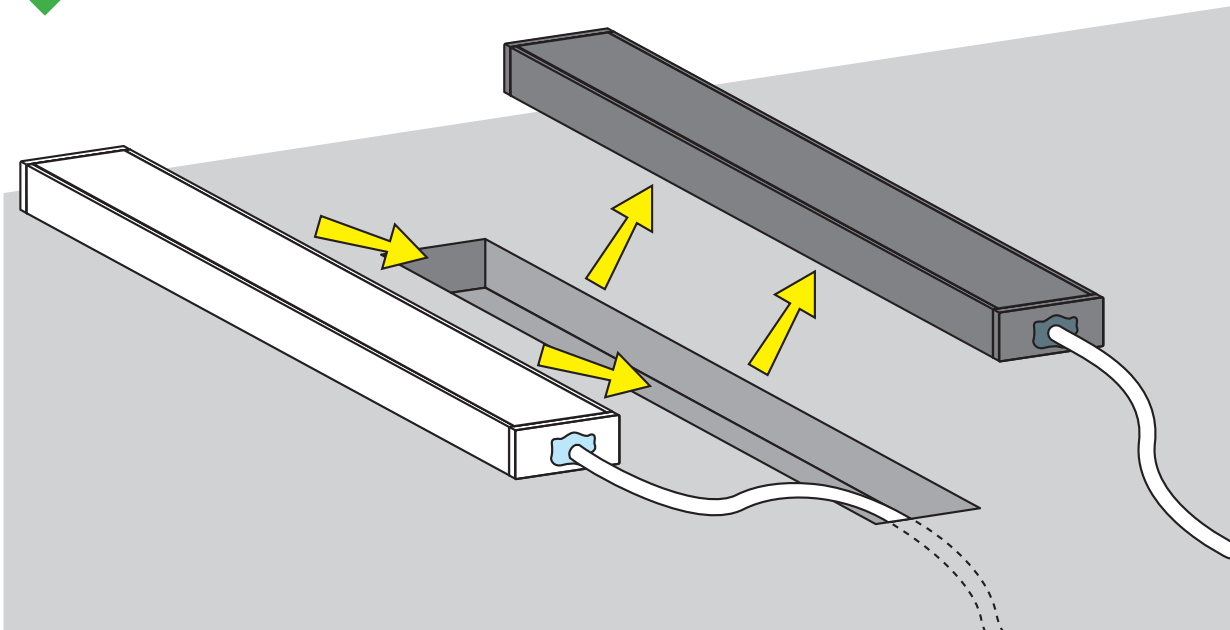
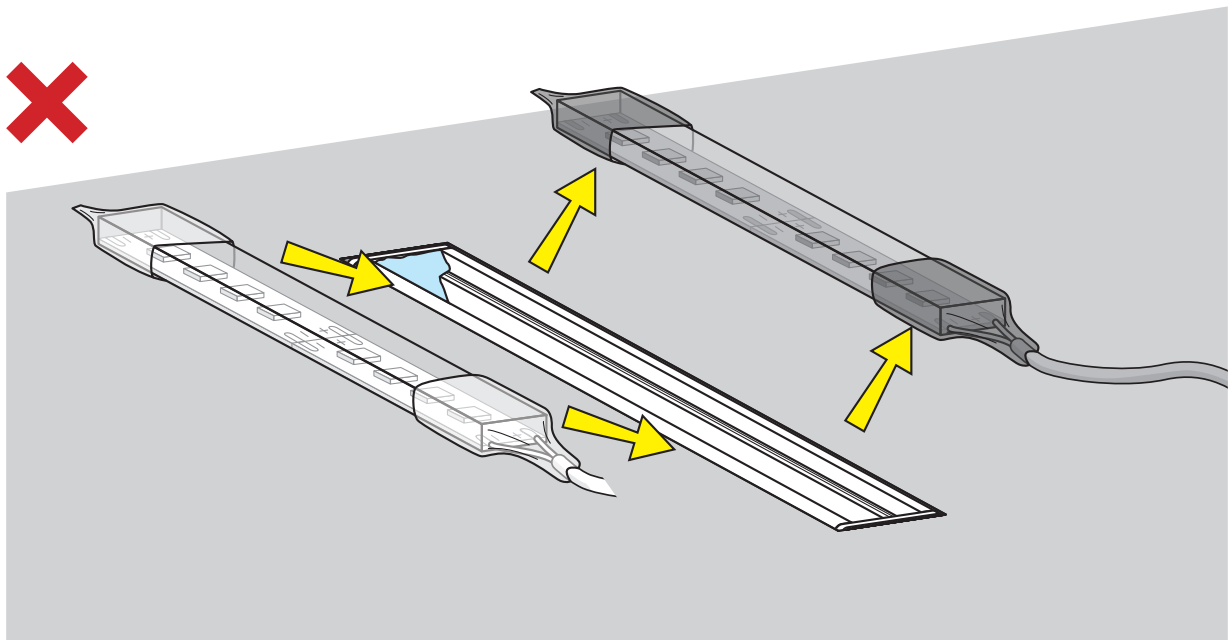

ATTENTION!

The light source in this fixture is not replaceable

When the LED strip is worn out, the entire fixture must be replaced

Disassembling and reassembling the fixture will not ensure proper sealing

Tech Light Sp. z o.o., as a supplier of components, is not responsible for the proper installation and sealing of the LED fixture.