

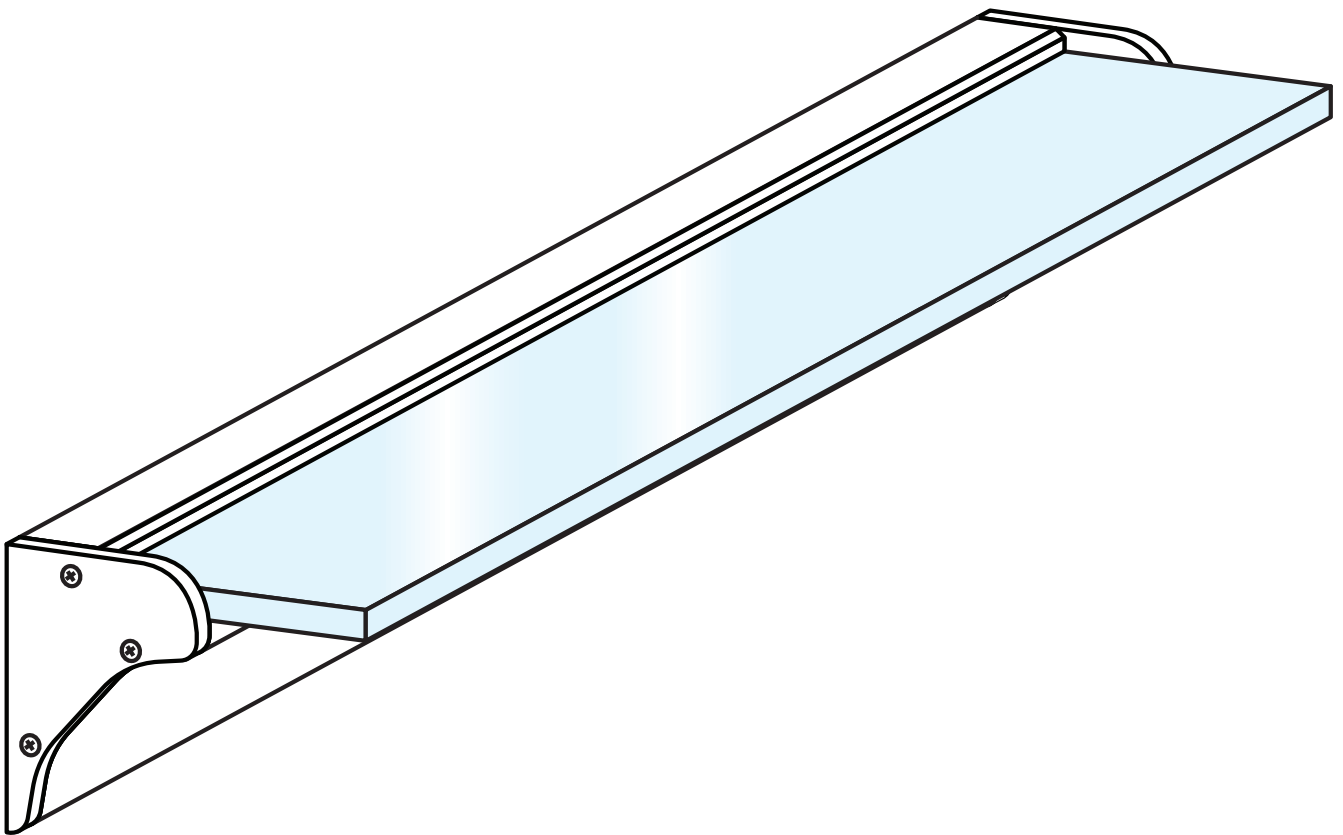

TECH[®]
LIGHT

INSTALLATION INSTRUCTIONS

standard glass profile



P10-8

CONTENTS

PROFILE PREPARATION	3
PROFILE INSTALLATION	4
LED TAPE INSTALLATION.....	5
GLASS INSTALLATION.....	6
ENDCAPS INSTALLATION	7
PRECAUTIONS.....	8

Attention!

The profile shown in the instructions may differ in appearance from the actual product. However, the installation method remains the same.

All profiles and covers have been manufactured with a positive tolerance.
They must be cut to the required length before installation.

PROFILE PREPARATION

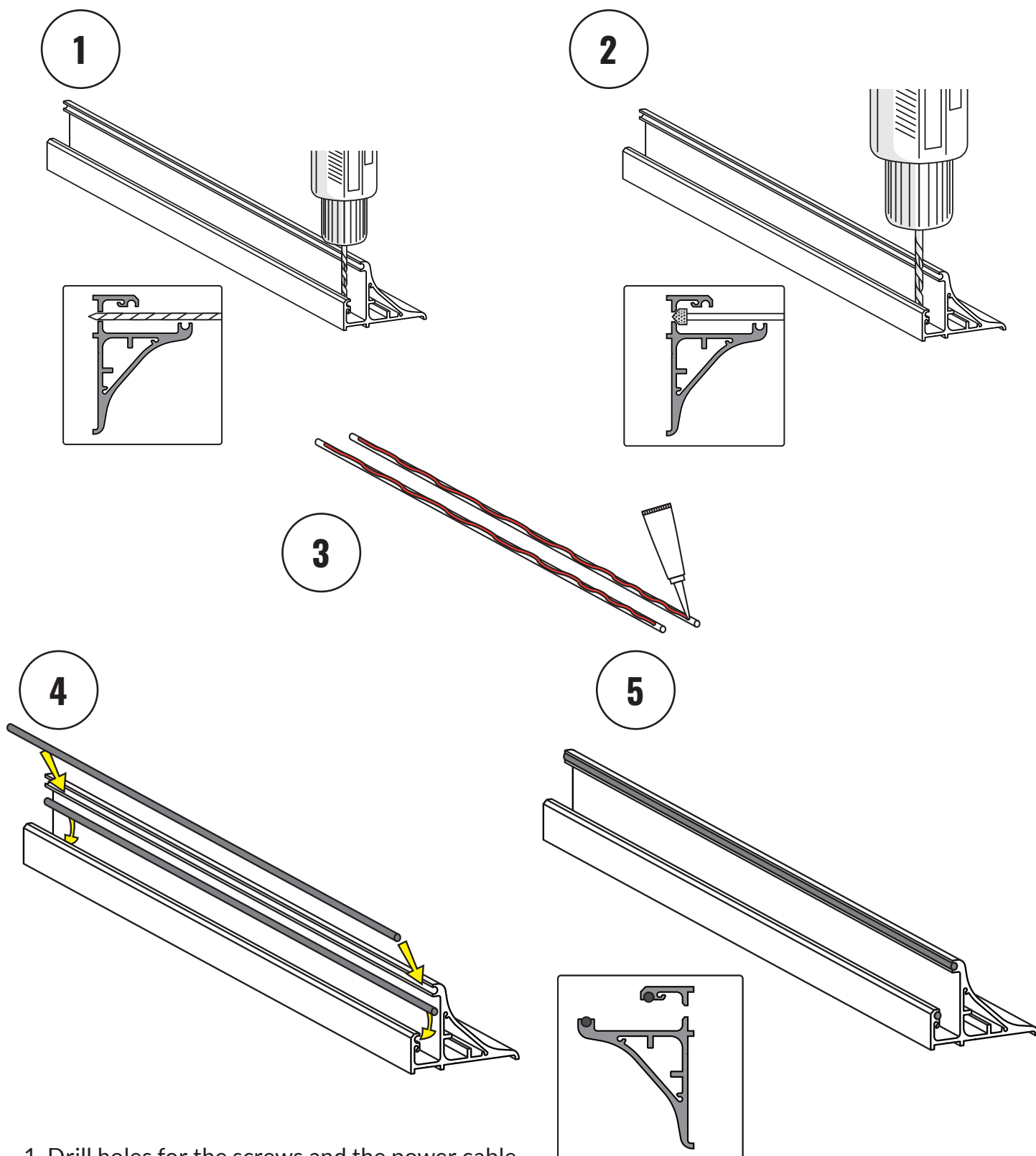

1. Drill holes for the screws and the power cable
2. Countersink the hole so the screw fits properly against the profile
3. Apply superglue to the rubber gaskets
4. Install the gaskets into the slots
5. The profile is ready for next step

PROFILE INSTALLATION

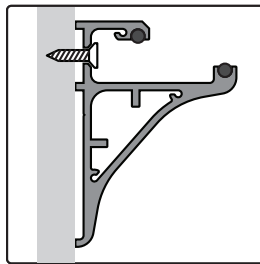
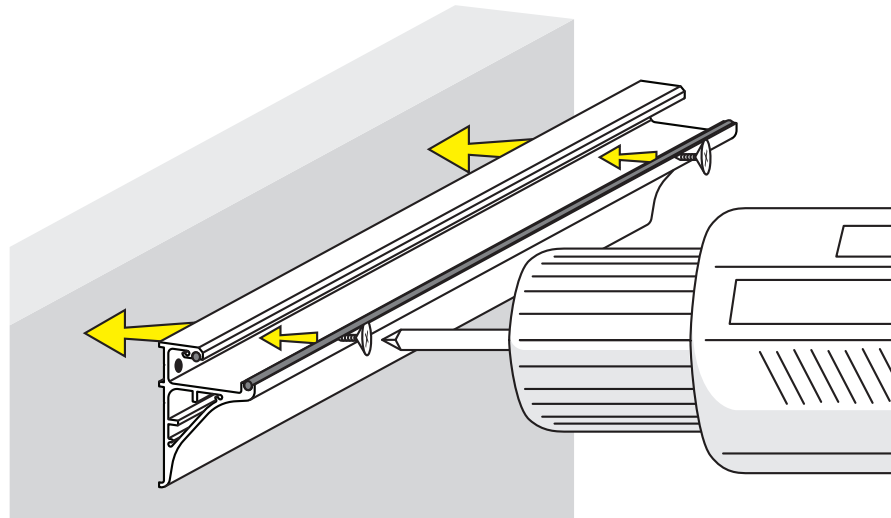
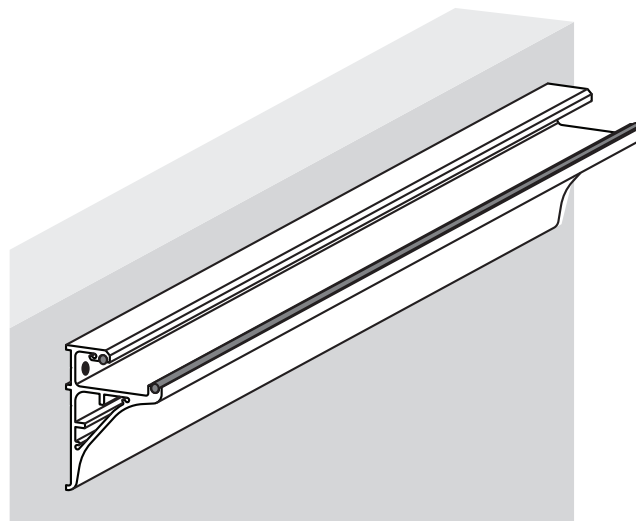
1**2**

1. Screw in the profile
2. The profile is screwed in

LED STRIP INSTALLATION

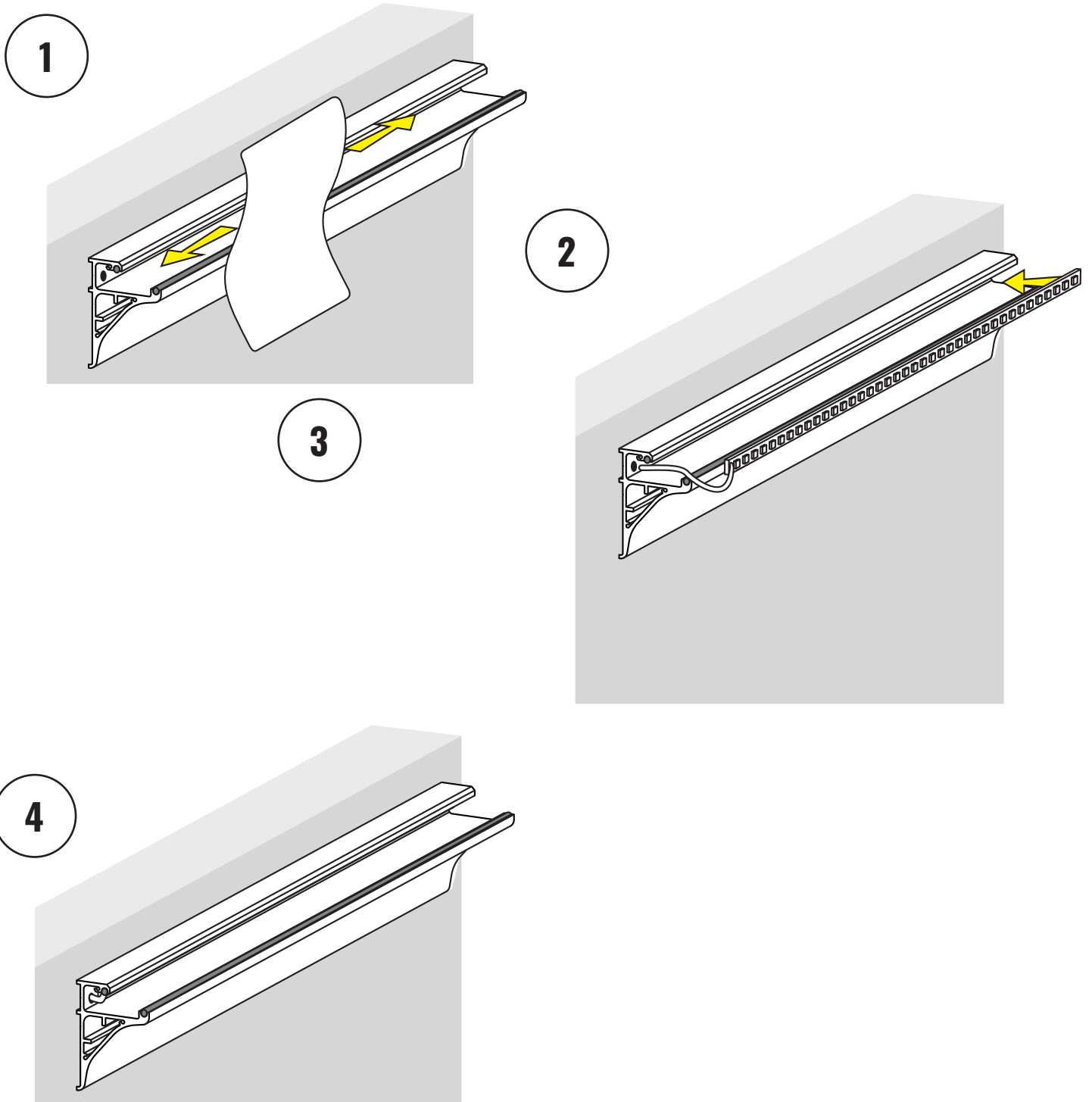

1. Clean the interior of dust and debris
2. Attach the LED tapes and route the power cables through the profile
3. The LED tapes are installed

GLASS INSTALLATION

WARNING!

The profile can support glass with a maximum depth of 25 cm.
The profile can support a maximum load of 10 kg.

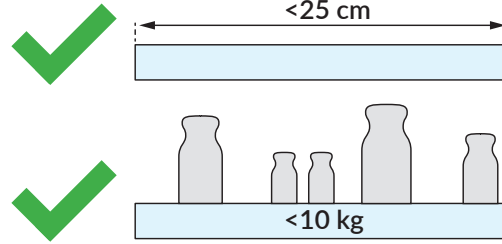

1

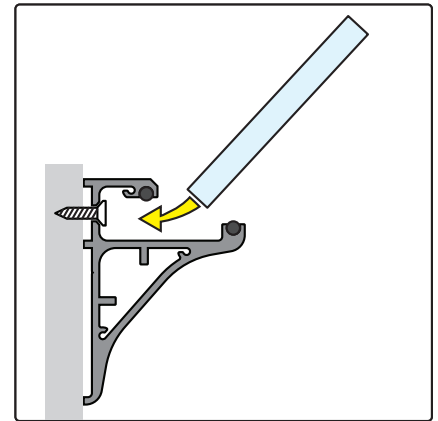
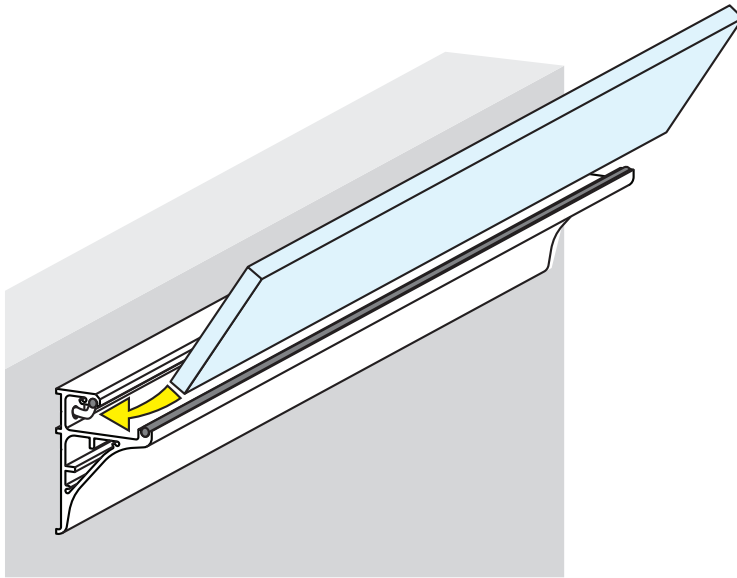

2

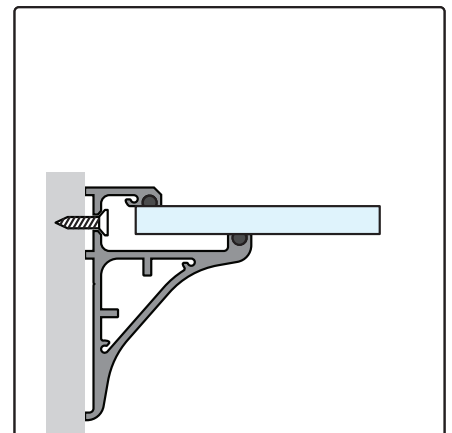
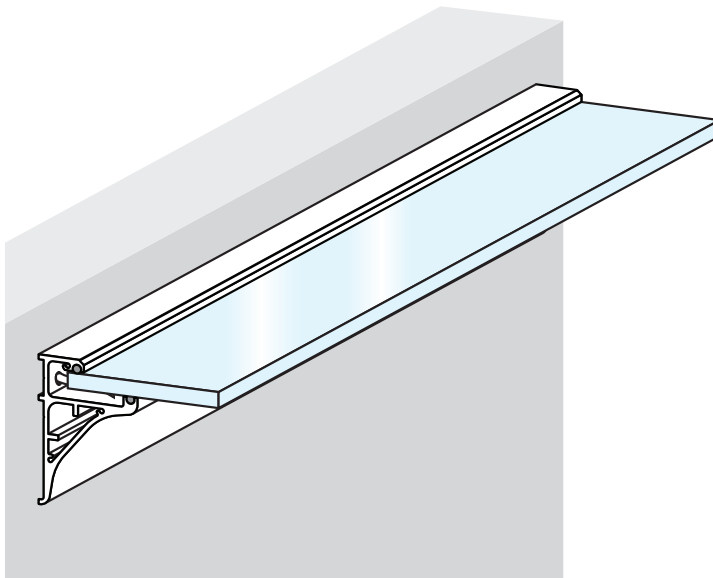

1. Insert the glass at an angle from above
2. The glass is installed

ENDCAPS INSTALLATION

1

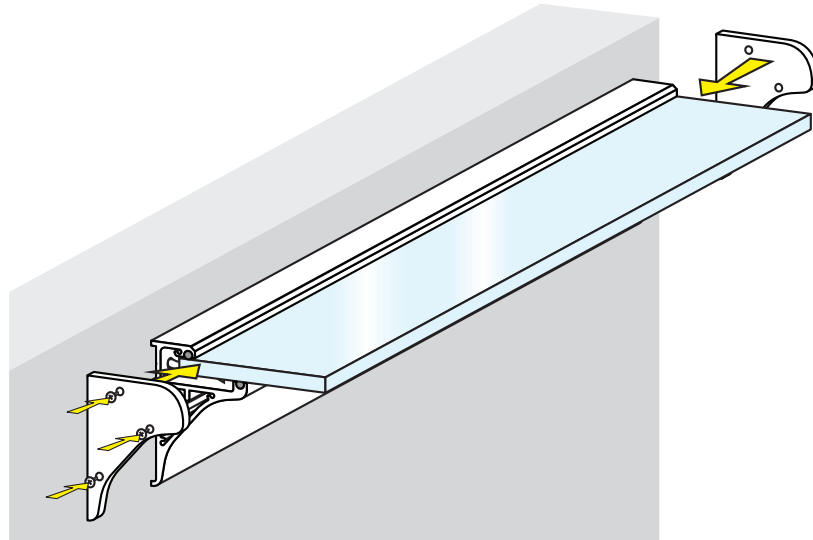

2

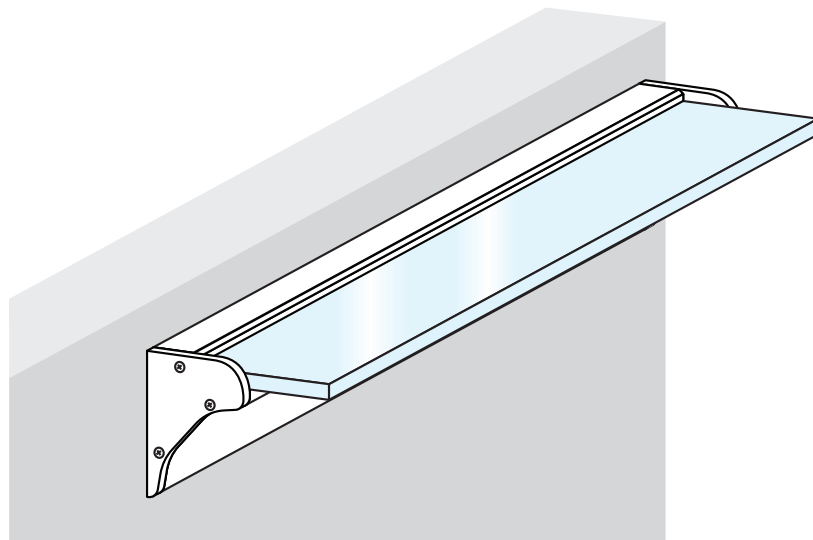

1. Install the top and bottom caps
2. The endcaps are installed

PRECAUTIONS

Warning!

Before installation, make sure the mounting surface is load-bearing and stable.

Do not overload the shelf. The maximum load is 10 kg.

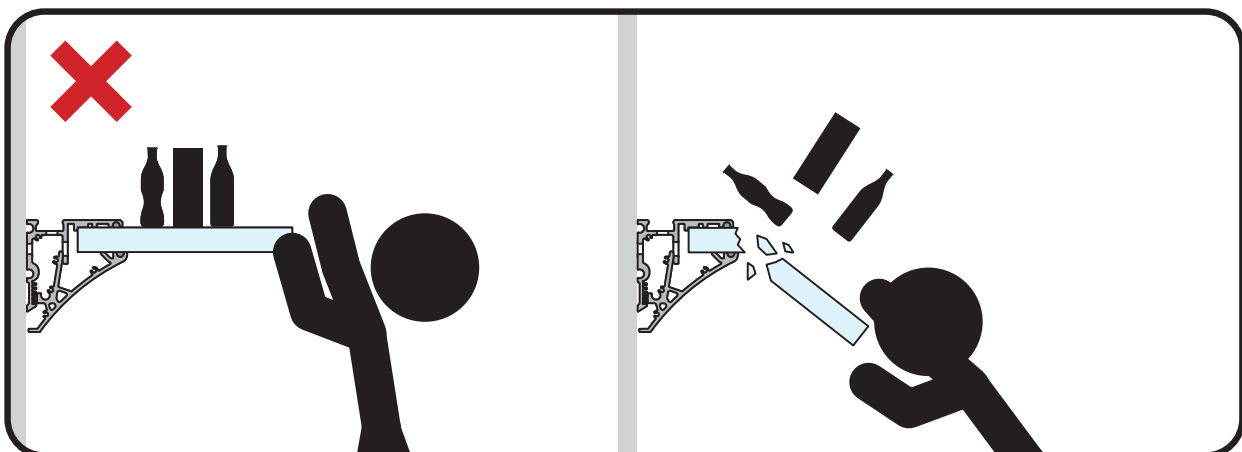
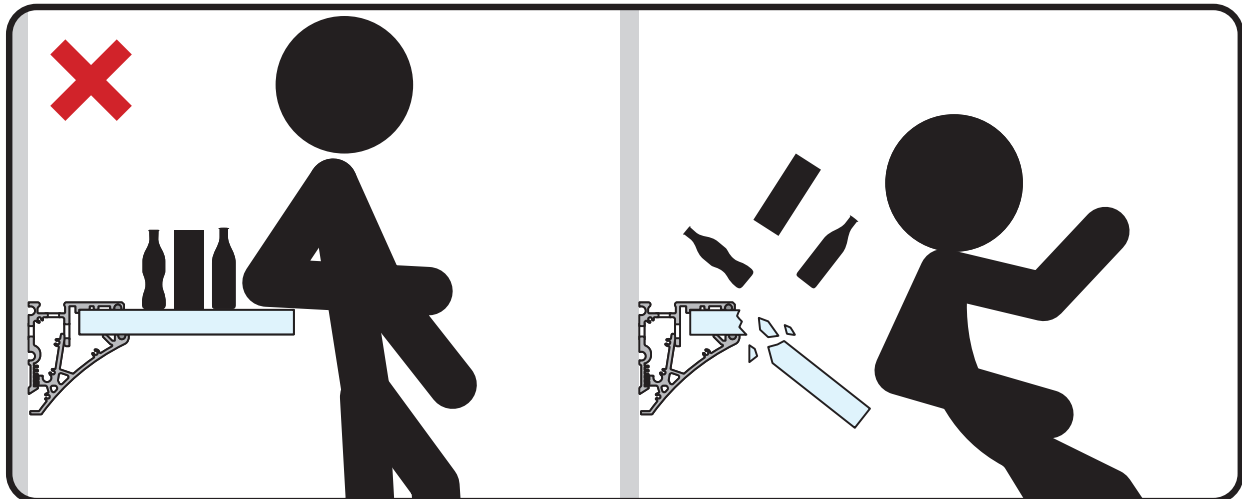

Do not lean on the shelf. Keep out of reach of children.

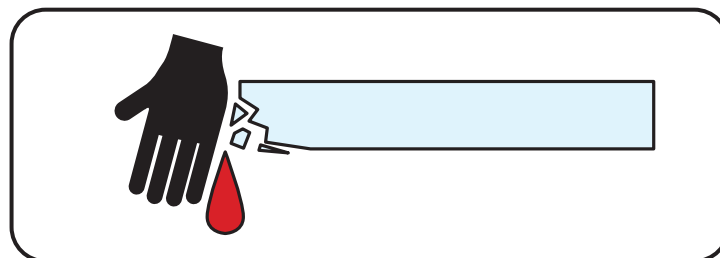

Do not install the shelf if the glass has cracks, chips, or other damage.

Under load, damaged glass may break and cause injury.

Tech Light Sp. z o.o., as a supplier of components, is not responsible for the proper installation and sealing of the LED fixture.